

2m cable,  
optional Spiral cable 1-5m

Front board control panel  
Pick-Up/Full-Mag/Safe/De-Mag

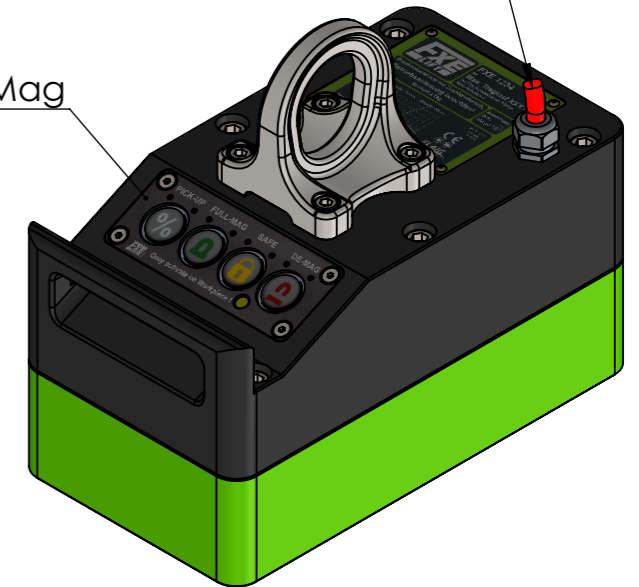

**Specification FXE 750-50+**

Nominative Force: 30,4kN	lifting capacity EN 13155/WLL
Materialthickness >15mm (100%)	WLL= 750kg
4,3 kVA	
U: 380-480V Pulse	Protection Class IP 65
R: 6,3Ω	Protectiv Earth SK I

**Max. Load capacity at sheets and 4-edge pipes**

T material thickness	Lmax (mm)	Wmax (mm)	Wll (kg)
>=4mm	1800	1500	150
>=6mm	2000	1500	250
>=8mm	2000	1500	400
>=10mm	2000	1500	600
>=15mm	3000	1500	750

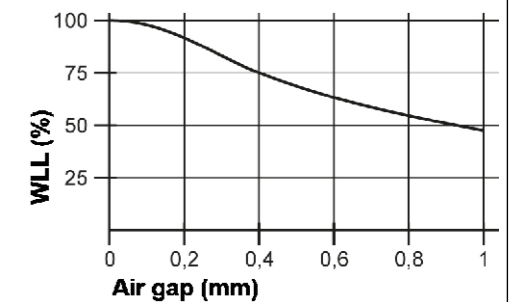
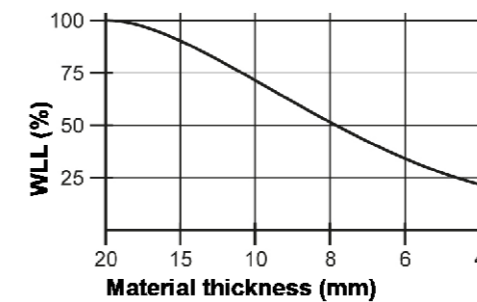

Schutzvermerk nach DIN ISO 16016 beachten!  
Nachdruck nur mit unserer Genehmigung!  
All rights reserved according to DIN ISO 16016!  
Reprint with our permission only!

	tolerance	-0,05 -0,2
	ISO	7168 M
	date	name
	drawn 23.10.2023	TW
	edit 23.10.2023	
	appr. 23.10.2023	TW

**FLAIG**  
Magnetsysteme  
www.flraig-te.de

material:	weight: 30kg
drawing no.:	<b>0017481</b>
description:	<b>FXE 750-50+</b>
part no.:	10600711
sheet	1 / 1
A3	
scale: 1:3	Status: Freigegeben